

FDV3 Indoor Medium-Voltage VCB with Embedded pole



فولمن
FULMEN

Contents

1. About Us
2. History Of Circuit Breakers
3. Embedded Pole Vacuum Circuit Breaker
 - 3.1 History and Development
 - 3.2 Technical Principle
 - 3.3 Advantages
4. **FDV3** Product Overview
 - 4.1 Description, Certification Application and Standards
 - 4.2 Types and Classification
 - 4.3 Operating Mechanism
5. **FDV3** Technical Characteristics
 - 5.1 FDV3,12KV/24KV
 - 5.2 FDV3,36KV
 - 5.3 Technical data for Auxiliary equipment
6. **FDV3** Control Diagram
 - 6.1 truck type VCB
 - 6.2 Fixed-type VCB
7. Overall Dimensions
8. Selection and Ordering Guide

1. About Us

With more than 40 years of experience in Power Transmission and Distribution (T&D), Fulmen is nationwide known as a pioneer in many areas. Engineering, Procurement and Construction (E.P.C.), Power Quality and Manufacturing of HV, MV and LV Equipment and Apparatus are among the areas that Fulmen has been recognized for his crucial influence and works.

Thanks to the years of experience and the latest developed technology and unique equipment, we provide our customers with variety of products in the highest level of quality and technology

We in Fulmen, strongly believe that, based on the Organization values and vision, the door of opportunity to participate effectively in Industrial domain is open for us.

We are especially interested those areas which attend the real need of customers and ultimately affect mostly our society.

We consider Quality not as a choice, but as a Prerequisite. Without Quality, no business will be carried out by us.



2. History of Circuit Breakers

Scientific developments in circuit breaking started in the year 1925. Bulk oil circuit breakers were developed with many improved features such as multi-break interrupter and axial flow blast interrupter to enhance the interrupting capacity. Bulk oil circuit breakers were widely used by industry in the medium voltage range from 1920 to 1970.

Development of minimum oil circuit breakers and air circuit breakers started almost simultaneously around the period 1930-35. The oil circuit breakers used alternative insulating material to achieve insulation between live and earth parts and a small volume of oil for arc interruption. In air circuit breakers, contact separation and arc extinction took place in air at atmospheric pressure. As the two current-carrying contacts are separated, an arc is drawn between them. The extinguishing force is generated in these breakers by elongating, cooling, splitting and/or constraining the arc. Air circuit breaker designs, developed during the period 1935-45, were more popular in the EHV range and did not find a place in medium voltage application due to the complexity of their design, high cost and problems of maintenance in compressed air systems.

Development work on circuit breakers using sulfur hexafluoride (SF₆) gas started in the 1950s and a few initial designs were made in early 1960s. The excellent dielectric properties of SF₆ gas helped in the rapid development of circuit breaker designs for medium voltage and extra high voltage.

However, in medium voltage application, vacuum circuit breaker and other contemporary technologies continued to be used along with SF₆ technology for quite some time. Finally vacuum circuit breaker, because of its simple and rugged design, low energy mechanism requirement, large number of switching operations and environment-friendly arc interruption feature, gained importance over the others. Vacuum circuit breaker virtually eliminated all other technologies in medium voltage application except SF₆ switchgear, which also found only limited usage.

Although development work on the use of vacuum as a switching medium started in the 1920s, the commercial vacuum interrupter for medium voltage application entered the market only in the 1960s. Its affordable price coupled with ease of handling and improved arc interruption behavior made it the leading technology in medium voltage circuit breaker, and the usage of oil and air circuit breakers was virtually eliminated. The two superior technologies, i.e. switching in vacuum and SF₆, continued to be used simultaneously in medium voltage application in the 1970s.

Finally, the present global market trend shows a clear dominance of vacuum circuit breaker in medium voltage application.

3. Embedded Pole vacuum Circuit Breaker

3.1. History and Development:

In medium voltage power system applications, recent international trends show that conventional types like oil, air and SF₆ circuit breakers are being mostly replaced by vacuum technologies. This technology will completely dominate the industry in coming years due to the fact that a vacuum circuit breaker represents an ideal solution to the widely varying demands of switching functions in medium voltage applications. Since they have been considered as a new phenomenon up to the present, Vacuum Interrupters have experienced numerous developments and innovations. Here below Table 1 shows a summary of cons and pros of different generations of vacuum circuit breaker manufacturing technologies.

3.2. Technical Principle:

Vacuum Interrupter

1. Axial magnetic field arc technology is of advantage to the electric field of vacuum interrupter, so the breaking stability and electric lifetime are highly improved.
2. The smaller resistance is of advantage to the temperature rising controlling of embedded pole.
3. Optimized electrical field of end face and structure design highly decrease the partial discharge of embedded pole, long-term operation lifetime is highly improved.



Different parts of Interrupters have been showed in figure1.

Figure 1



Embedded Pole VCB

Table 1: explains 3 generations of VCB and trend of their features.

VCB Type	Different Generations of VCB		
	1ST (Cantilever type)	2nd (Assembled pole)	Latest (Embedded pole)
Criteria			
Mechanical protection Level	Very Low Direct exposure of interrupter	Low Indirect exposure of interrupter	Best No access to interrupter
Dielectrical protection	Low Exposure of ceramic surface of the interrupter to dust & humidity	Very Low Dust and humidity lock within poles	Best No air flow inside poles No ceramic exposure to humidity and dust
Surface protection Against corrosion & pollution	Low Exposure of ceramic surface to corrosive material	Very Low pollutions lock within poles	Best No air floe inside poles No ceramic exposure to corrosive material.
Dimension	Big Using air as dielectric results in bigger size	Big Using air as dielectric results in bigger size	Small No air flow inside poles No ceramic exposure to corrosive material
Direct Cost	Low	Medium	High
Actual Cost for End User Direct Cost+Maintenance Life Time	High	High	Low
Heat dissipation	High Free Convection	Low Radiation -forced convection conduction	High Conduction
Mechanical stability Against short circuit stresses	Low	Low	High

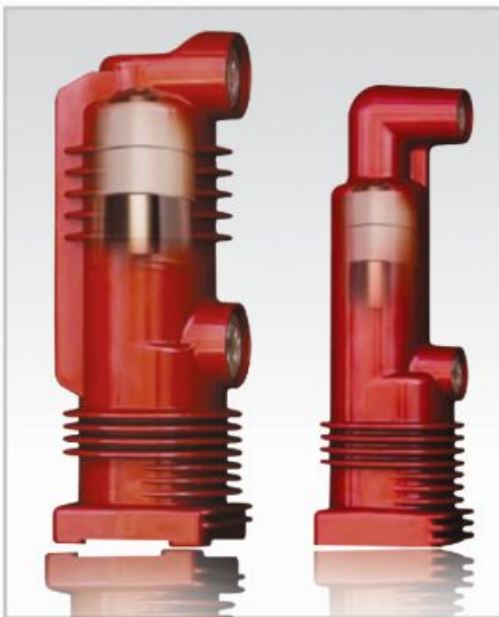

3.3. Advantages:

1. High reliable

Comparing with traditional assembled pole, embedded pole has less part, contact surface and fastening hardware, it simplifies the assembly of main circuit and decreases the resistance, so it has higher connection reliability for main circuit.

2. Stable insulation level

Vacuum interrupter was embedded in the epoxy resin through APG process, the influence of ambient environment to the vacuum interrupter is decreased to the minimum, its insulation level can be free from the external dust, humidity and dew etc.

3. More stable structure

It protects the vacuum interrupter against the mechanical collision during the assembly or transportation process.

4. Small volume

As epoxy resin works as the insulation medium, it makes the pole distance smaller and decreases the volume of switch-gear at the same time.

5. Maintenance free

Since the pole is injected as a whole part, the vacuum interrupter is protected and it provides the condition of maintenance free for VCB.

6. Low total cost

Although the direct cost of embedded pole VCB is a quiet high, considering other impressive parameters like, low dimensions, expected lifetime and maintenance, total cost is low for end user.

4. FDV3 Product Overview

4.1. Description, Applications, Certification and Standards:

FDV3 indoor type medium Voltage VCB is an embedded pole type Vacuum Circuit breaker. Design of this VCB is an outcome of mutual collaboration between Fulmen experts and a highly respected German design team. The breaker embedded poles are made with APG process, make its vacuum interrupter with super lower resistance and upper/lower contacts directly embedded in epoxy resin, it forms the third generation of solid insulation way.

FDV3 series, a third and latest generation of VCB, not only avoids the possibility of the leakage and damage during transportation or installation made by the first generation air insulation cantilever type VCB, but also fully avoids the insulation decreasing made by the second generation VCB as static electricity adsorption onto ceramic surface of the interrupter. The third generation embedded poles are maintenance-free within its lifetime.

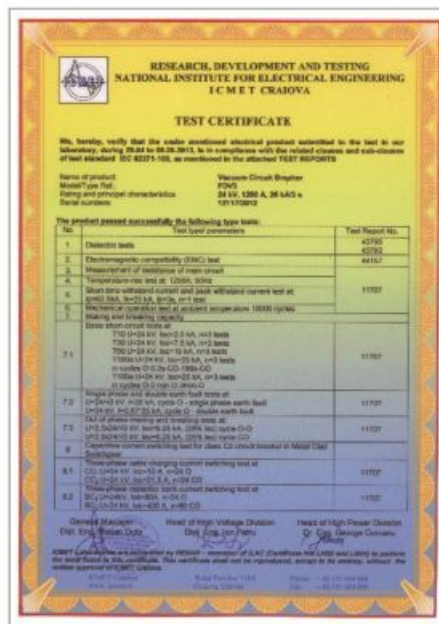

- Type test certificates for 24kV, 1250A and 2500A VCBs obtained from ICMET Laboratory, Romania.

Applications:

FDV3 vacuum circuit-breakers are used in power distribution for protection of cables, overhead lines, transformer feeders, distribution feeders, motors, generators and capacitor banks. FDV3 series MV embedded pole VCB can be used in power plants, power grid, petrochemical industry, oil and gas industry, metallurgy and city infrastructures such as subway and airport facilities and so on.



Standards:

Applicable standards for FDV3 are:

IEC 62271-100

IEC 60694

The products are tested and certified according to abovementioned standards.

FDV3 Product Overview

4.2. Types and Classifications:

Installation Types:

FDV3 VCBs are available in following installation types:

Fix type: For fix installation, lower cost

Truck type: For withdrawable installation, applicable for more reliable network.

Rated Voltage:

The rated voltage of FDV3 VCBs is:
12kV up to 36kV

Rated Current:

The rated current of FDV3 VCBs is:
630A up to 3150A*

* For 36kV, max available rated current is 2500A.

Note: Detail technical information has been mentioned in section 5.



4.3. Operating Mechanism:

FDV3 VCB adopts high reliable and efficient spring mechanism. It decreases the equipment failure rate by simplifying the mechanism and increasing the machining precision.

Re-design the unique release system, it makes the opening current release and over current release require less energy to act, it also means releases act more stable and reliable.

It uses long-term lubricant or oil-free bearing for each friction parts and it makes the mechanism works more reliable.

It uses components with special surface treatment technology and it increases the capability of wear resistance and corrosion resistance for all metal components.

Whole complete design with compact mechanism, all module mechanisms arrange obviously and it makes the maintenance to be easier.

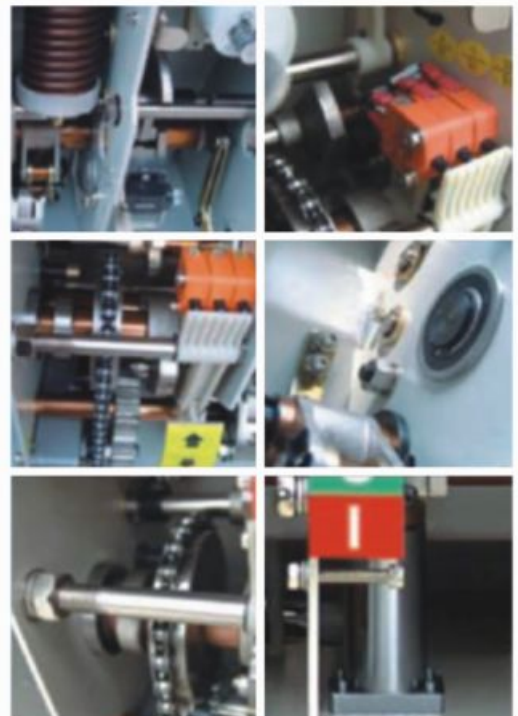

5. FDV3 Technical Characteristics

5.1. Main technical data for 12kv/24kv FDV3

Descriptions / Units		VCB type designation						
		FDV3-12				FDV3-24		
Applied Standards	IEC 62271-100	•				•		
	VDE 0670-100	•				•		
Rated voltage	Ur [kV]	12				24		
Rated insulation voltage	Us [kV]	12				24		
Rated power frequency withstand voltage	Ud (1 min) [kV]	42				65		
Rated lightning Impulse withstand voltage	Up [kV]	75				125		
Rated frequency	fr [Hz]	50				50		
Rated normal current (40 °C)	Ir [A]	630	630	630	-	630	630	630
		1250	1250	1250	1250	1250	1250	1250
		-	-	1600	1600	-	-	1600
		-	-	2000	2000	-	-	2000
		-	-	2500	2500	-	-	2500
		-	-	3150	3150	-	-	-
Rated short-circuit breaking current	Isc [kA]	20	25	31.5	40	20	25	31.5
Rated short-time withstand current	Ik/tk [kA/s]	20/4	25/4	31.5/4	40/4	20/4	25/4	31.5/4
Rated peak withstand current	Ip [kA]	50	63	80	125	50	63	80
Mechanical endurance	Basic [M1:2000 operations]	-				-		
	Extended [M2:10000 operations]	•				•		
	No. of operations	30000			20000	10000		
Electrical endurance	Basic [E1]	-				-		
	Extended [E2]	•				•		
Switching operations under rated short-circuit breaking current	Times	50				50		
Operation sequence	[O - 0.3 s - CO - 180 s - CO]	•				•		
	[O - 180 s - CO - 180 s - CO]	•				•		
Opening time	[ms]	25 ... 35				25 ... 35		
Arcing time	[ms]	10 ... 15				10 ... 15		
Total breaking time	[ms]	35 ... 50				35 ... 50		
Closing time	[ms]	60 ... 70				60 ... 70		
Overall dimensions	H x W x D + Pole distance [mm]	Please refer to section 7						
Weight	[kg]	110 ~ 230 (refer to section 7)				145~240 (refer to section 7)		
Operating temperature	[°C]	- 5 ... +40				- 5 ... +40		

FDV3 Technical Characteristics

5.2. Main technical data for 36kv FDV3 VCB

Please contact us for technical data of 36KV VCB.

5.3. Technical data for Auxillary equipment

Table 2: Shunt opening/closing release

Un	110/220V AC/DC
Operating limits	70-110% Un
Inrush power	DC: 220W ; AC: 220VA
Inrush time	Approx. 100ms
Continuous power	DC: 5W ; AC: 5VA
Opening time	25-35
Closing time	60-70ms
Insulation voltage	2500V 50Hz (for 1 min)

Table 3: Under voltage release

Un	110/220V AC/DC
Operating limits for CB opening	35-70% Un
Operating limits for CB closing	85-110% Un
Inrush power	DC: 220W ; AC: 200VA
Inrush time	Approx. 100ms
Continuous power	DC: 5W ; AC: 5VA
Opening time	35ms
Insulation voltage	2500V 50Hz (for 1 min)

Table 4: Auxillary contacts of the circuit breaker

Un	110/220V AC/DC
Rated current	10A
Insulation voltage	2500V 50Hz (for 1 min)
Electrical resistance	3mOhm

Table 5: Locking magnet on the truck

Un	110/220V AC/DC
Operating limits	85-110% Un
Inrush power	DC: 220W ; AC: 220VA
Inrush time	Approx. 100ms
Continuous power	DC: 5W ; AC: 5VA

Table 6: Motor operator

Un	110/220V AC/DC
Operating limits	85-110% Un
Rated power	DC: 90W ; AC: 90VA
Charging time	4-10s
Insulation voltage	2500V 50Hz (for 1 min)

6. FDV3 Control Diagram

6.1. Control Diagram for truck type VCB

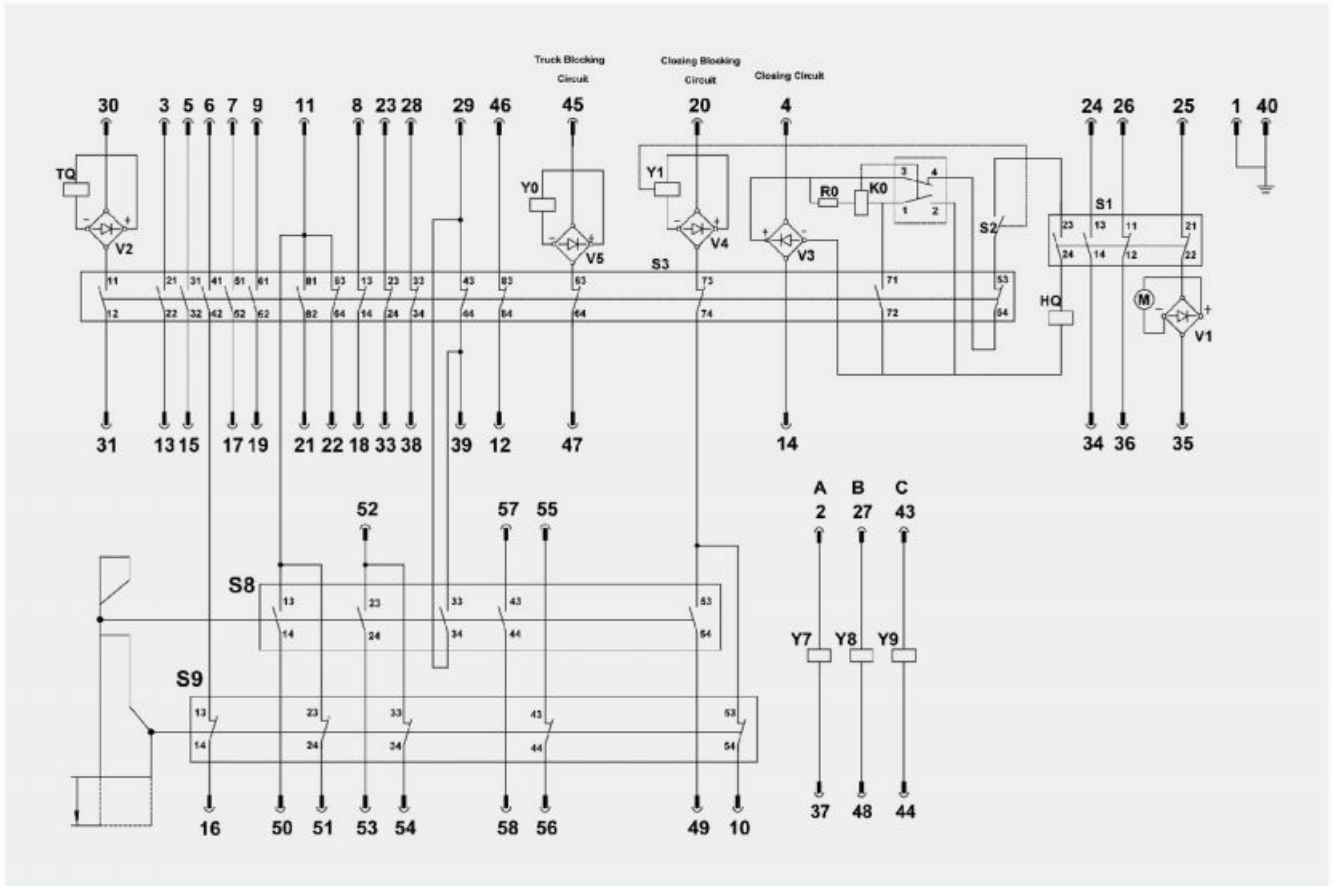

Item	Name
Y0	Truck Blocking Electromagnet (Elective)
Y1	Closing Blocking Electromagnet
TQ	Tripping Release
HQ	Closing Solenoid
Y7 - Y9	Over-current release
S1	Position Switch of the Charging Motor
S2	Auxiliary Switch of the closing Blocking Electromagnet
QF	Auxiliary Switch of Circuit Breaker
S8	Position Switch of Test
S9	Position Switch of Work
M	Charging Motor
KQ	Internal Anti-pumping Relay
RO	Resistance adaptor for Auxiliary
V1~ V4	Rectifier Cell

Note: The diagram is sketched when the circuit breaker is opened and the operating mechanism is in non-charged position.

7. FDV3 Overall Dimensions

12kV External Dimension for truck type VCB

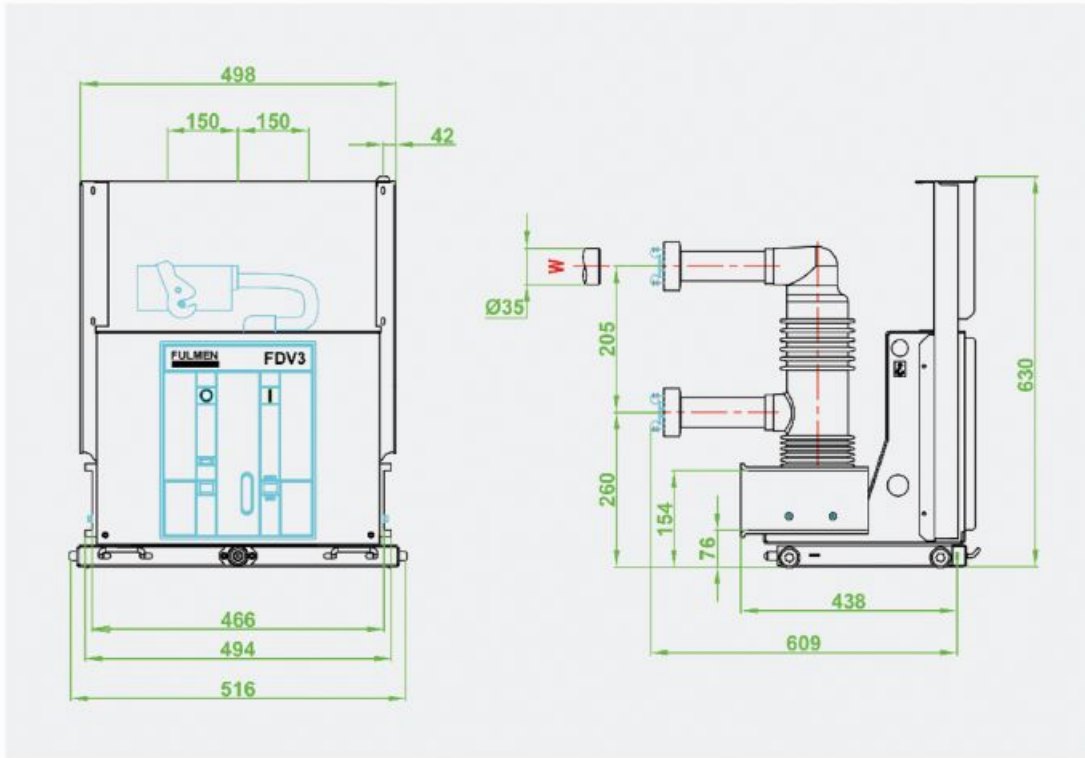

12kV External Dimension for fixed type VCB

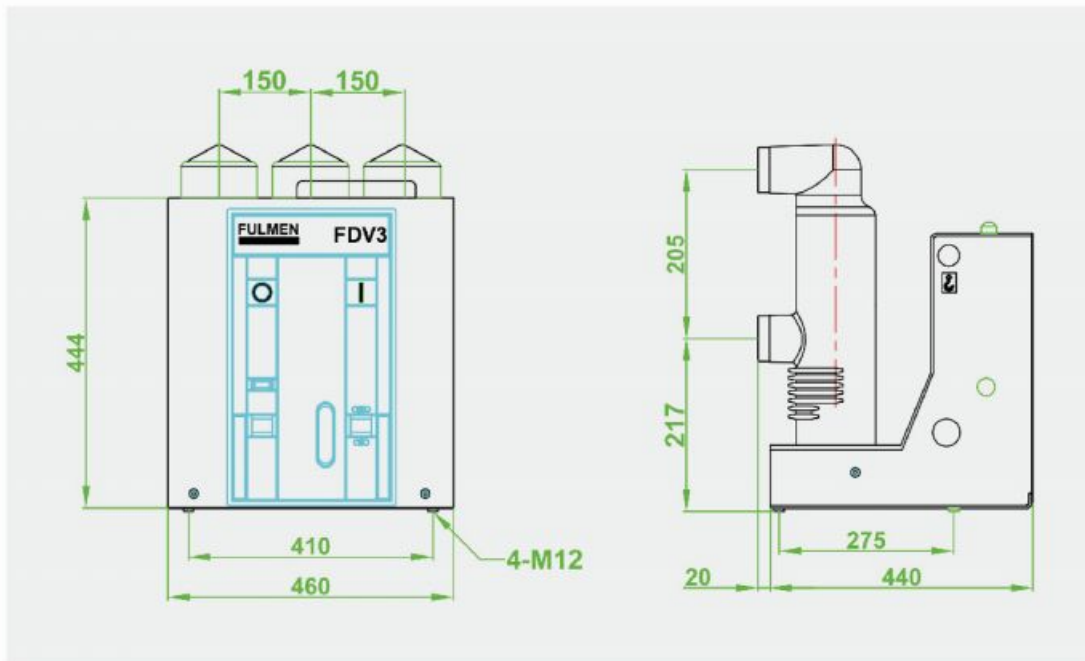

FDV3 Overall Dimensions

12kV External Dimension for truck type VCB

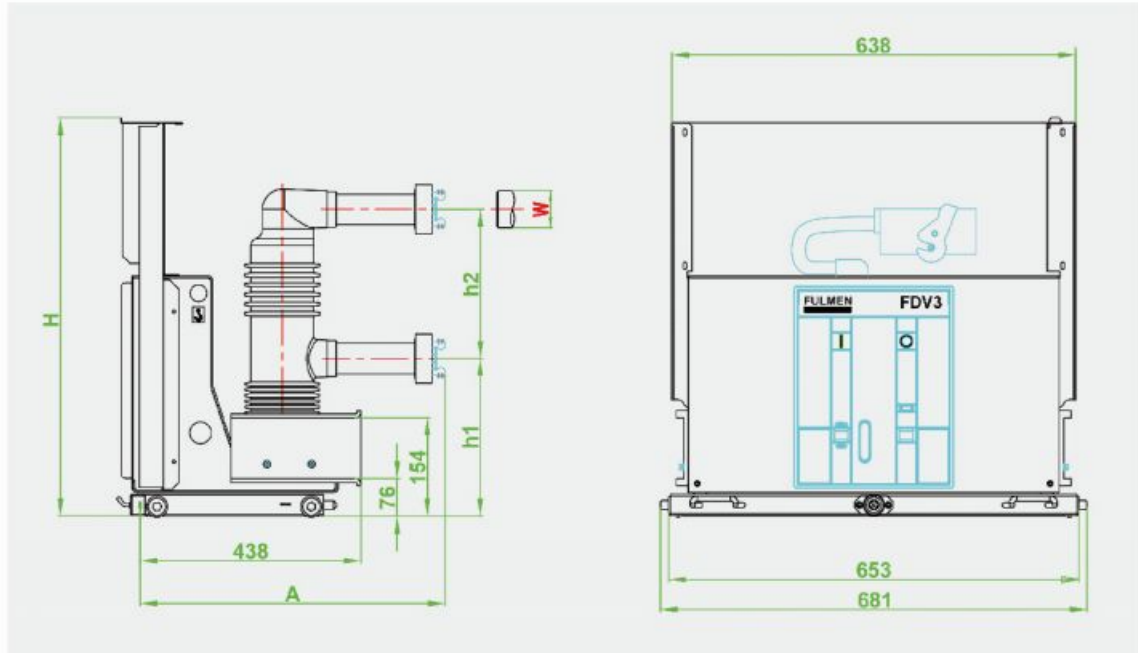

Type	W	h1	h2	H	A
630A	∅35	260	205	618	609
1250A	∅49	280	275	637	600

12kV External Dimension for fixed type VCB

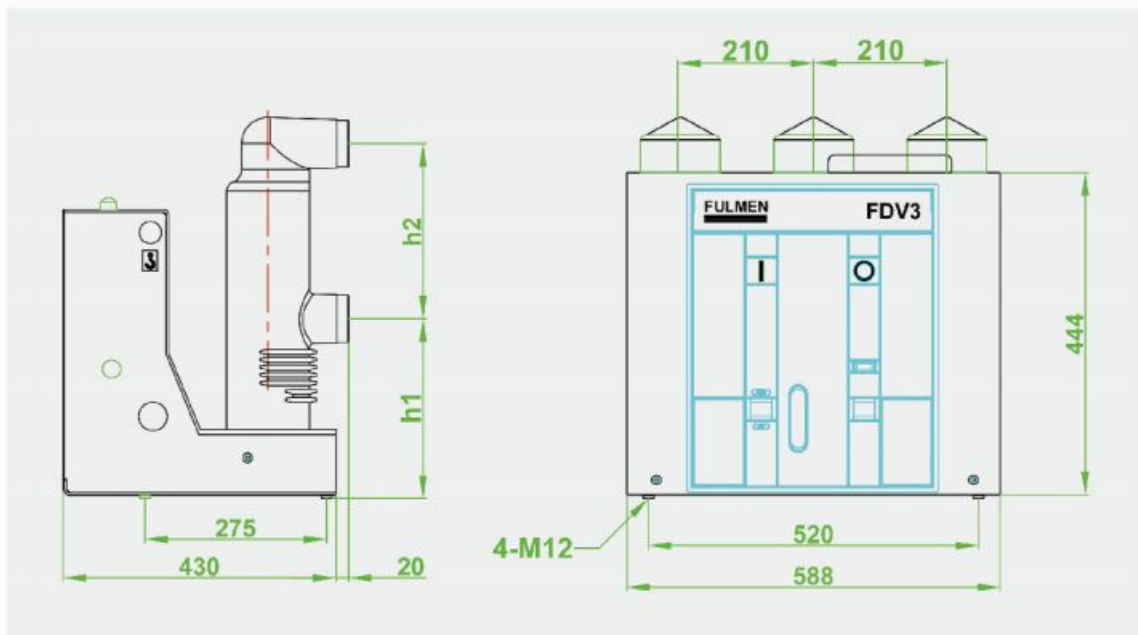

Type	h1	h2
630A ... 1250A	217	205
	237	275

FDV3 Overall Dimensions

12kV External Dimension for truck type VCB

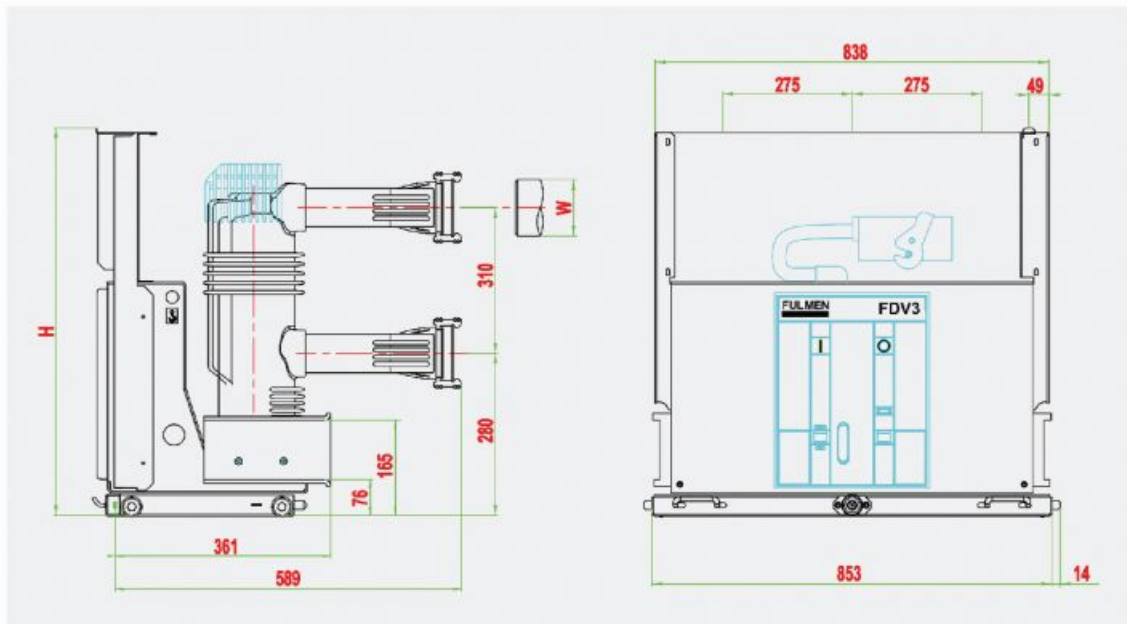

Type	W	H
1600A ... 2000A	∅79	694
2500A ... 3150 A	∅109	735

12kV External Dimension for fixed type VCB

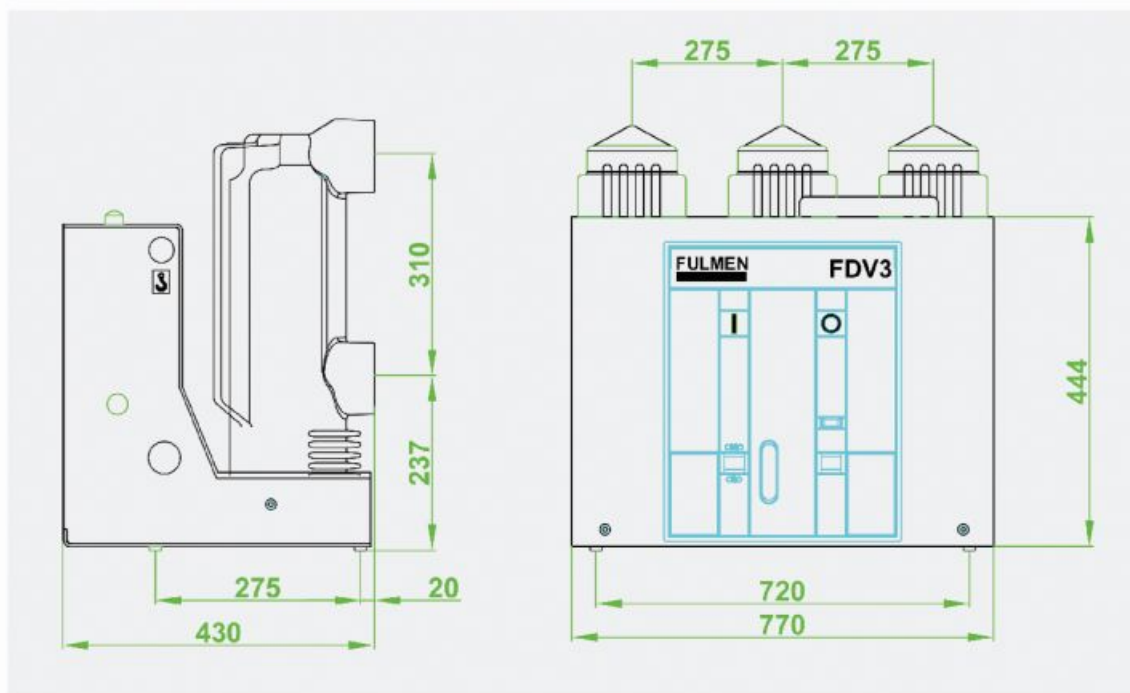

Type
1600A ... 2000A ... 2500A ... 3150A

FDV3 Overall Dimensions

24kV External Dimension for truck type VCB

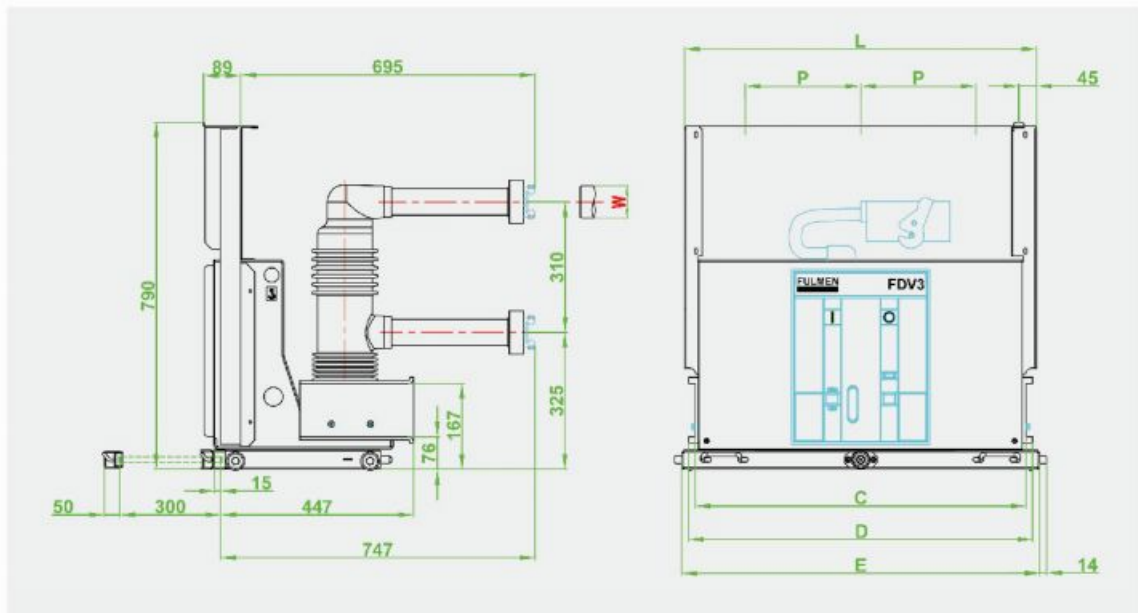

Type	P	C	D	E	L	W
630A	210	622	646	653	643	∅ 35
1250A	210	622	646	653	643	∅ 49
630A	275	818	842	853	844	∅ 35
1250A	275	818	842	853	844	∅ 49

24kV External Dimension for fixed type VCB

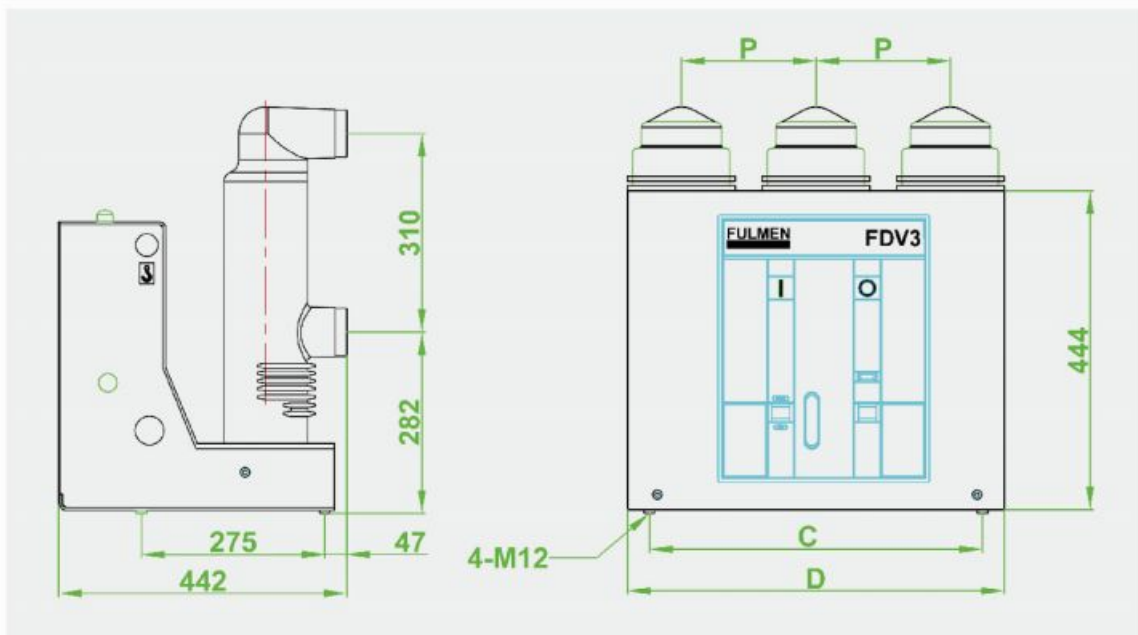

Type	P	C	D
630A ...1250A	210	520	588
	275	720	770

FDV3 Overall Dimensions

24kV External Dimension for truck type VCB

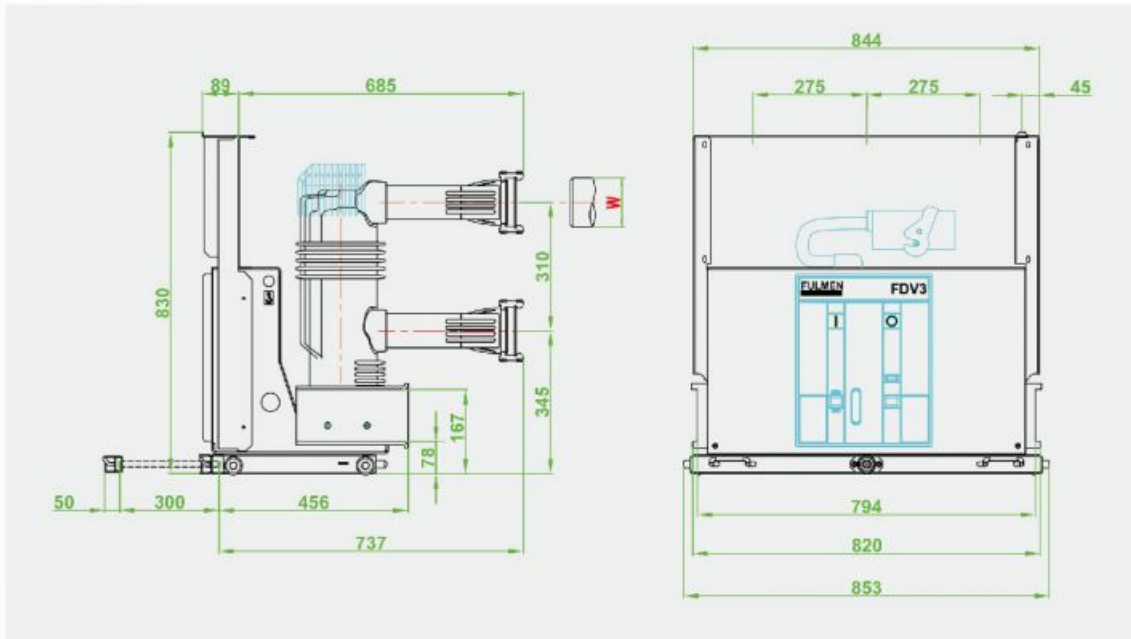

Type	W
1600A	ø 79
2000A	ø 79
2500A	ø109
3150A	ø109

24kV External Dimension for fixed type VCB

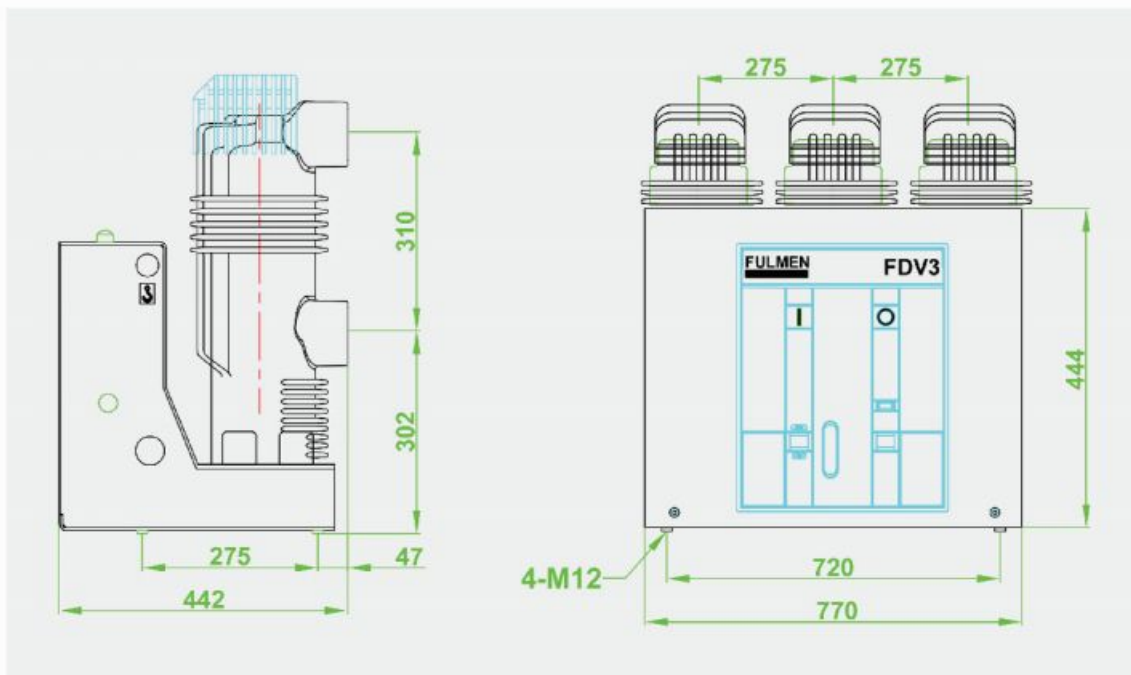

Type
1600A ... 2000A ... 2500A ... 3150A

8. FDV3 Selection and Ordering Guide

Following parameters should be indicated by clients for ordering:

1) Type code:

- a. **F:** Fix Type
- b. **T:** Truck Type

2) Rated Voltage:

According to below table:

Table 1			
Voltage (KV)	12	24	36
Code	E	G	I

3) Rated Current:

According to below table:

Table 2						
Current (A)	630	1250	1600	2000	2500	3150
Code	K	L	M	N	P	Q

4) Rated short circuit withstand current(3S):

- a. **A:** 20KA
- b. **B:** 25KA
- c. **D:** 31.5KA
- d. **F:** 40KA

5) Distance between poles (mm):

- a. **W:** 150
- b. **X:** 210
- c. **Y:** 275

6) Aux. power Supply:

According to below table:

Table 3							
Aux. power supply	DC24V	DC48V	DC110V	DC125V	DC220V	AC110V	AC230V
Code	A	C	E	G	J	K	M

7) Altitude above sea level (ASL)

- a. <1000m : **N**
- b. <1700m : **U**

FDV3 Selection and Ordering Guide

Designation Code:

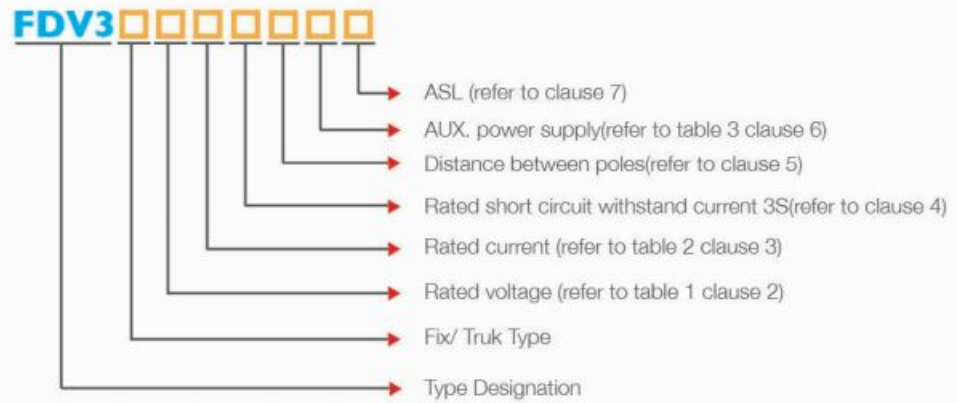

Note: Clients could make order by "Designation Code" or by indicating full technical specifications.

Fulmen Co.

No. 2, Danesh Alley, South MehrAbad

Tehran, IRAN

P.O. Box.: 19395/1371

T (+98 21) 6349 23 00

F (+98 21) 6349 23 30

www.Fulmen.com

www.Panir-Co.com